



MANCHESTER Series

MC12-P

Full Size 12" Point Source Asymmetrical Element for Install and Touring

MC12-P-SB

Swivel Bracket for MC12-P Loudspeakers

MC12-P-YB

Yoke Bracket for MC12-P Loudspeakers

SA-35

Stand Adapter for Turbosound Yoke Brackets to 35mm Speaker Stands

TQ-FB

Fly Bar for TQ and MC12-P Series Loudspeakers

Safety Instruction

1. Read these instructions.
2. Keep these instructions.
3. Heed all warnings.
4. Follow all instructions.
5. Do not use this apparatus near water.
6. Clean only with dry cloth.
7. Do not block any ventilation openings. Install in accordance with the manufacturer's instructions.
8. Do not install near any heat sources such as radiators, heat registers, stoves, or other apparatus (including amplifiers) that produce heat.
9. Use only attachments/accessories specified by the manufacturer.



10. Use only with the cart, stand, tripod, bracket, or table specified by the manufacturer, or sold with the apparatus. When a cart is used, use caution when moving the cart/apparatus combination to avoid

injury from tip-over.



11. Correct disposal of this product: This symbol indicates that this product must not be disposed of with household waste, according to the WEEE Directive (2012/19/EU) and your national law. This product should be taken to a collection center licensed for

the recycling of waste electrical and electronic equipment (EEE). The mishandling of this type of waste could have a possible negative impact on the environment and human health due to potentially hazardous substances that are generally associated with EEE. At the same time, your cooperation in the correct disposal of this product will contribute to the efficient use of natural resources. For more information about where you can take your waste equipment for recycling, please contact your local city office, or your household waste collection service.

12. Do not install in a confined space, such as a book case or similar unit.
13. Do not place naked flame sources, such as lighted candles, on the apparatus.

LEGAL DISCLAIMER

Music Tribe accepts no liability for any loss which may be suffered by any person who relies either wholly or in part upon any description, photograph, or statement contained herein. Technical specifications, appearances and other information are subject to change without notice. All trademarks are the property of their respective owners. Midas, Klark Teknik, Lab Gruppen, Lake, Tannoy, Turbosound, TC Electronic, TC Helicon, Behringer, Bugera, Aston Microphones and Coolaudio are trademarks or registered trademarks of Music Tribe Global Brands Ltd. © Music Tribe Global Brands Ltd. 2023 All rights reserved.

LIMITED WARRANTY

For the applicable warranty terms and conditions and additional information regarding Music Tribe's Limited Warranty, please see complete details online at community.musictribe.com/pages/support#warranty.

Welcome

Thank you for choosing a Turbosound loudspeaker product for your application. If you would like further information about this or any other product, please visit our website at turbosound.com.

Unpacking the Loudspeaker

After unpacking the unit, please check carefully for damage. If damage is found, please notify your supplier at once. You, the consignee, must instigate any claim. Please retain all packaging in case of future return shipment.

About this Quick Start Guide

This QSG describes details of the MC12-P loudspeaker and shows various options such as the TQ-FB fly bar, MC12-P-YB yoke bracket, MC12-P-SB swivel bracket, and SA-35 pole mount bracket, in readiness for suspending or pole mounting. These instructions shall only be used with these components.

The optional rigging components (TQ-FB fly bar, MC12-P-YB yoke bracket, MC12-P-SB swivel bracket, SA-35 pole mount bracket) shall only be used in conjunction with Turbosound MC12-P loudspeakers as described in this quick start guide.

The instructions do not show details of external lifting equipment and do not contain details of safe lifting procedures or installation.

Possession of these instructions and procedures does not imply authorisation for their use.

General Safety

The operation of your product as part of a suspended system, if installed incorrectly and improperly, can potentially expose persons to serious health risks and even death. In addition, please ensure that electrical, mechanical and acoustic considerations are discussed with qualified and certified (by local, state or national authorities) personnel prior to any installation.

Installation and setup should only be carried out by qualified and authorised personnel observing the valid local, state and other safety regulations applicable in your country. If any parts or components are missing please contact your dealer before attempting to set up the system.

It is the responsibility of the person installing the assembly to ensure that the suspension/fixing points are suitable for the intended use.

We also recommend you schedule Turbosound training with our sales partners and applications team.

Equipment used to connect to the Turbosound rigging system must be properly rated and must conform to the local, state and other safety regulations. Do not use Turbosound rigging with other types or brands of loudspeakers. This practice may compromise safety standards and Music Tribe Global Brands Ltd will not be responsible for damage or injury so caused. Do not modify the accessories, or use them in a way other than that described in this QSG. Rigging components supplied as part of a complete assembly are non-interchangeable and must not be exchanged with the component parts of any other assembly.

Welding, or any other means of permanently fixing rigging components to each other or to cabinet fixing points is not allowed. Rigging components or assemblies must only be fixed to Turbosound loudspeaker cabinets using the cabinet fixing points.

Music Tribe Global Brands Ltd assumes no liability for any damage or personal injury resulting from improper use, installation or operation of the product. Regular checks must be conducted by qualified personnel to ensure that the system remains in a secure and stable condition. Make sure that, where the product is suspended, the area underneath the product is free of human traffic. Do not suspend the product in areas which can be entered or used by members of the public.

Always refer to EASE Focus 3 modeling software error and warning indications prior to installation.

Secondary Safeties

All loudspeakers flown in theatres, studios or other places of work and entertainment shall, in addition to the principle load bearing means of suspension, be provided with an independent, properly rated, and securely attached secondary safety. Only steel wire ropes or steel chains of an approved construction and load rating shall be used as secondary safeties. Plastic-covered steel wire ropes are not permitted for use as secondary safeties.

The secondary safety suspension must be independent of the primary suspension points and capable of carrying the total system weight. The additional safety device must be mounted in a way that the loudspeaker is caught by the safety device without any drop and swing, in the event that the primary suspension fails.

Operational Safety

The procedures require the use of two or more authorised persons.

Produce a lift plan: before any lift takes place, you must formulate a lift plan that describes the exact steps and procedures that will be carried out.

The plan must be shared with all assistants and stake-holders in the lift so that each person will understand their responsibilities.

Observe all instructions given on the respective instruction labels of the rigging components and loudspeakers.

When using chain hoists, make sure nobody is directly underneath or in the vicinity of the loudspeakers.

During assembly pay attention to the possible risk of crushing.

Wear suitable protective clothing.

Safety Inspections

Carefully inspect rigging system components and cabinets for defects or signs of damage before proceeding to assemble the array to be flown. If any parts are damaged or suspect, or if there is any doubt as to the proper functioning and safety of the items DO NOT USE THEM and withdraw them from use immediately.

System Requirements

The MC12-P is a bi-amp 3-way loudspeaker with a passive network used on the mid and high frequency bands, and it requires 2 channels of amplifier and DSP in bi-amp mode. It also is switchable to fully passive mode that requires 1 channel of amplifier and DSP.

All Manchester series Loudspeakers exclusively use LAKE pre-sets via Lab Gruppen PLM+ and D series L platforms. No other amplifier and DSP platforms are supported.

Manchester series has a powerful yet simple pre-set strategy utilizing the latest functionality of LAKE software (explained later in this QSG).

Pre-set data is found either via the LAKE LOAD Library or can be downloaded from www.turbosound.com

Recommended Lab Gruppen PLM+ models for Touring applications are the PLM12k44 and PLM20k44.

For installations using Lab Gruppen D series L models, please use Lab Gruppen 'CAFE' software - available for download from www.labgruppen.com - to determine the optimum amplifier configuration for your system.

System Cabling Requirements

To avoid wasting amplifier power, you should use heavy-duty speaker cable with a minimum wire size of 2.5 mm² (14 AWG), and preferably 4 mm² (12 AWG) for longer runs or where total cabinet input impedance is less than 8 ohms. For extreme cable lengths, be aware of cable impedance and resistive losses.

Always observe the correct polarity.

Use genuine NEUTRIK SPEAKON CONNECTORS for reliable operation.

Attach and support the speaker cables from your amplifiers to the loudspeaker cabinets, so that no significant additional weight or lateral force is applied to the array by the input wiring. Input cables or link cables should never be used to angle the array or used as rigging in any way.

Bi-Amp Mode

NOTE: Since the MC12-P cabinet in BI-AMP MODE is wired (1+/- = LF and 2+/- = MHF), it makes sense to use either (LF: 1 +/- HF: 2 +/-) or (LF: 3 +/- HF 4 +/-) for the output patching from the Lab Gruppen PLM+ amplifier

Move the rear panel switch to the BI-AMP position

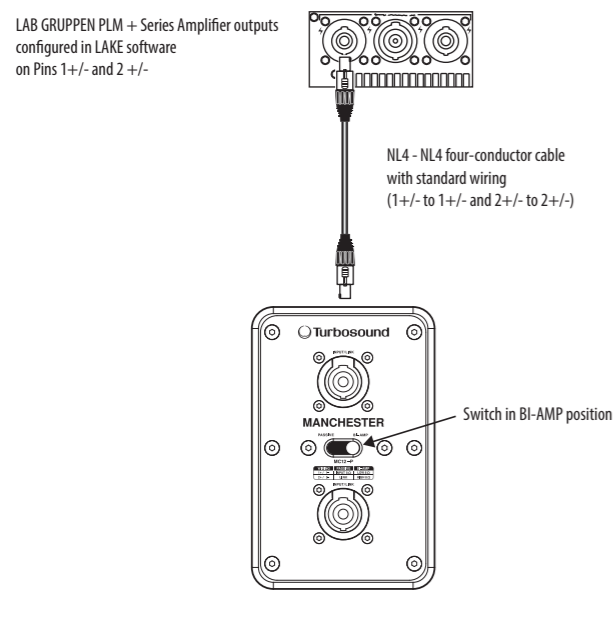

Processed Passive Mode

Note: Since the MC12-P cabinet in Processed Passive mode is wired (1+/- = LF and 2+/- = link), the output patching can be selected from any of the 4 options (1, 2, 3, 4 +/-) from the Lab Gruppen PLM+ amplifier.

Depending on how the other channels are used (for example in a stereo system with two MS12-P and two MS121 subwoofers) it may be useful to use "NL4 to 2-NL2 breakout splitter cables," as shown in the example below.

The NL4 end uses Pin 1 +/- and Pin 2 +/- and both NL2 ends need to be wired Pin 1 +/-

Note: in this case, do not use the subwoofer's front input, as it uses Pin 2 +/- connected to the woofer.)

Move the rear panel switch to the PASSIVE position.

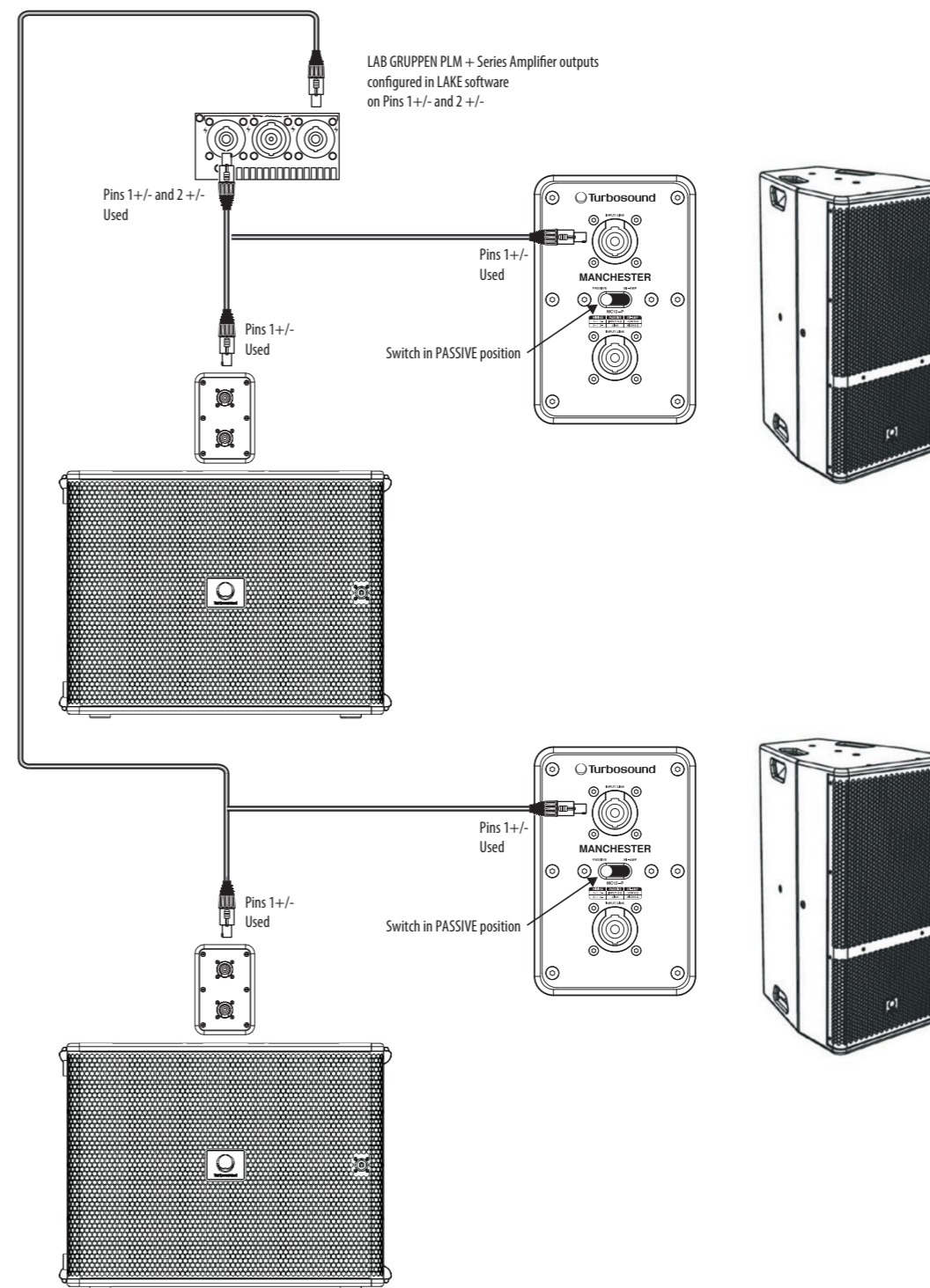

Connections

Caution: It is mandatory to use the official factory Lake pre-set. Failure to do so will result in component failure of the MC12-P passive crossover and transducers. No other 3rd party DSP or Amplifiers are supported

Mode	Back Panel	Connector	Internal Schematic
MC12-P Bi-Amp Mode		<p>BI-AMP, Input Low +</p> <p>Amplifier Channel 1 → 1-</p> <p>BI-AMP, Input Low - → 1+</p> <p>BI-AMP, Input High +</p> <p>Amplifier Channel 2 → 2-</p> <p>BI-AMP, Input High - → 2+</p>	<p>NL4 Input/Link</p> <p>1+ → LF 1</p> <p>1- → LF 1</p> <p>2+ → MHF</p> <p>2- → MHF</p>
MC12-P Processed Passive Mode		<p>Full Range Input + → 1-</p> <p>Full Range Input - → 1+</p>	<p>NL4 Input/Link</p> <p>1+ → LF 1</p> <p>1- → LF 1</p> <p>2+ → MHF</p> <p>2- → MHF</p>

Rigging and Acoustic Simulation Software

The MC12-P has 3 main rigging accessories: the TQ-FB (Fly Bar), The MC12-YB (Yoke Bracket) and the MC12-SB (Swivel Bracket) these accessories comply with BGV-C1 rigging standards.

The MC12-P is not an arrayable product, however it is supported in Ease Focus 3 for either stand alone use, with Manchester series subwoofers or as a fill or delay speaker as part of larger Manchester series systems.

EASE Focus 3 is an acoustic simulation program, available as a free download from <https://www.afmg.eu/en/ease-focus>



Full EASE data can be downloaded from www.turbosound.com
This will allow acoustic prediction, array formation and suspension to be determined. Important safety information about WLL is also calculated by EASE Focus.

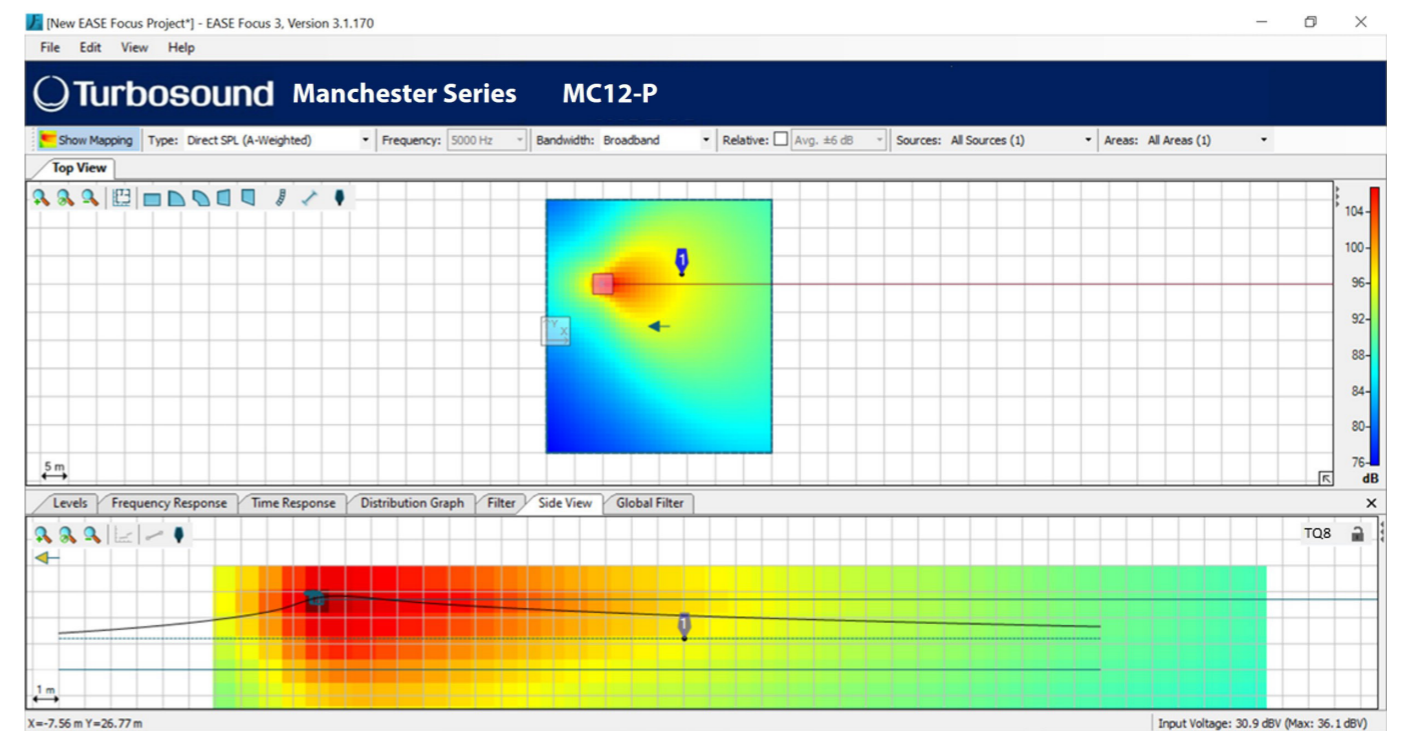

MC12-P Installation

Safety Warning: Only authorised and certified personnel shall design and install suspended configurations. Incorrect installation may lead to death or permanent injury.

The use of a secondary safety is a mandatory safety requirement.

The versatile MC12-P has integral pole mount holes, and has ten M10 mounting holes with fitted hex socket head screws.

The optional accessories allow the MC12-P to be mounted in a number of different configurations.

M10 Mounting Holes with Screws

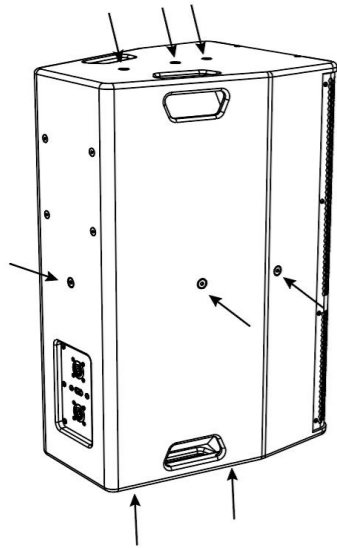

Pole Mount

Two 35 mm holes are provided for pole mounting, one in the vertical position, and one with the MC12-P tilted forward. The MC12-P can be pole mounted on an MS121 subwoofer, or on a suitable tripod stand.

We recommend using a 35 mm pole with an M20 thread at the lower end. This type provides more security and will screw into the top receptacle of the MS121 subwoofer.

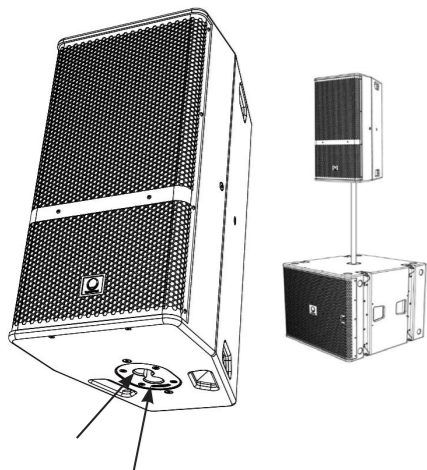

Fly Bar TQ-FB

The optional TQ-FB fly bar allows the speaker to be flown. It has ten pick points for attaching shackles, and it bolts to the top of the MC12-P.

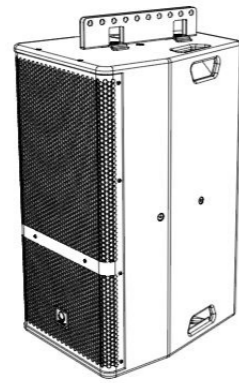

The flybar fits to the top of the MC12-P speaker using two of the existing M10 screws as shown. Securely tighten both screws.

The flybar has 10x 12.5 mm diameter holes that are used as pick points for rigging shackles. The space between each rail of the TQ-FB allows for a standard 1 ton bow shackle to be used to pick up the MC12-P.

Either style of shackle will work:

W.L.L = 1 Ton
 A = 10 mm
 B = 11 mm
 C = 17 mm
 D = 36.5 mm

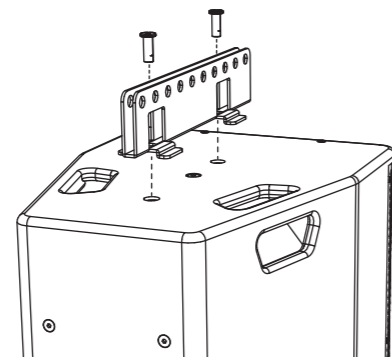
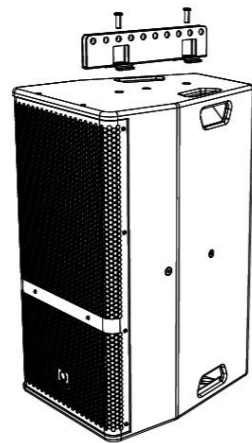
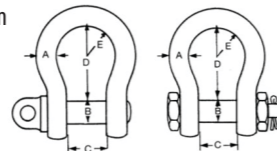

Yoke Bracket MC12-P-YB

The optional MC12-P-YB yoke bracket allows the MC12-P to be flown using suitable hook clamps or couplers to then fix to a flown truss. Ratcheting handles are provided on either side to help angle the speakers accurately and secure them.

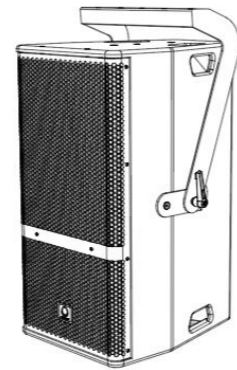

The yoke bracket fits to the sides of the MC12-P speaker, using two M10 25mm bolts per side, supplied with the MC12-P-YB. Note that the yoke bracket is oriented as shown.

Securely tighten both screws on each side. The speaker tilt can be accurately adjusted after first slackening off the ratchet handles on either side and tilting the speaker to the desired angle. Then tighten the handles to secure the speaker in position.

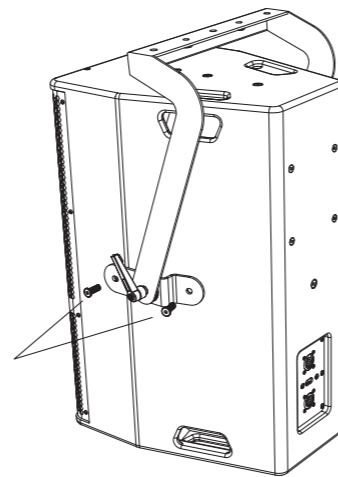

If the yoke bracket is to be bolted to a ceiling or other surface, then secure the yoke bracket first.

Then attach the side brackets to each side of the speaker, and lift the speaker and attach it to the yoke bracket with the pivot handles. Adjust the speaker angle and tighten the handles.

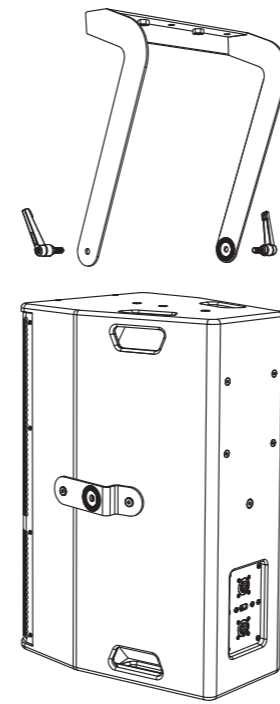

Pole Mount SA-35

The optional SA-35 bracket allows the yoke bracket to support the MC12-P on a 35 mm pole mount or tripod.

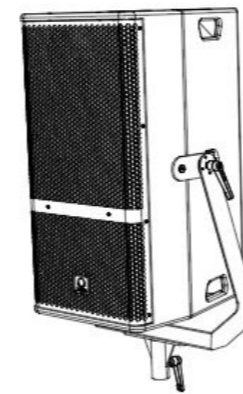

The SA-35 bracket attaches to the MC12-P-YB yoke bracket with two screws.

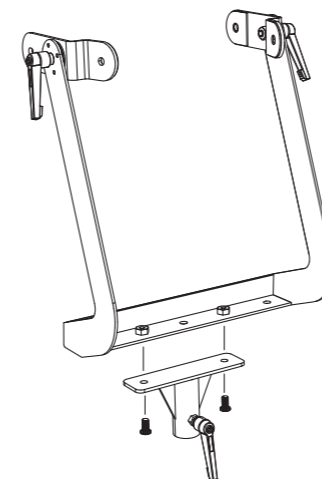

The MC12-P-YB with SA-35 attached can then be attached to the speaker as before. Note the orientation is as shown.

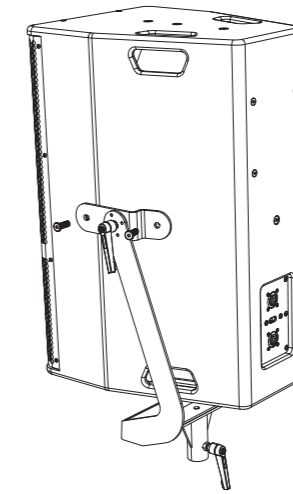

The assembly can then be added to a 35mm pole mounted to an MS121 subwoofer, or to a suitable tripod. Tighten the SA-35 ratchet handle to secure the assembly to the pole or tripod. Adjust the speaker tilt as desired and tighten the handles on each side.

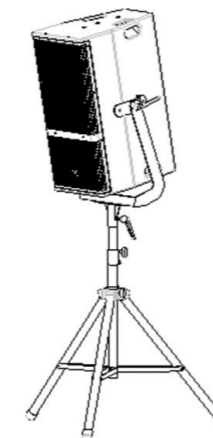
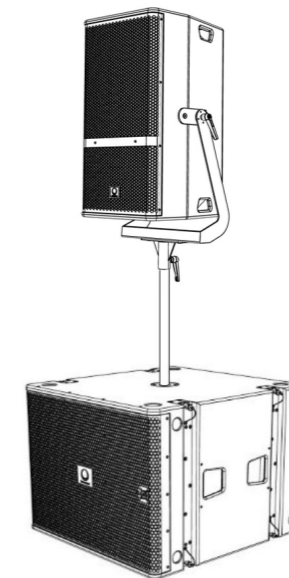

Swivel Bracket MC12-P-SB

The optional MC12-P-SB swivel bracket allows the MC12-P to be ceiling or wall mounted horizontally, or truss-mounted using suitable hook clamps. The speaker angle can be accurately set and clamped in position. Two concentric rows of holes allow for a wide range of angle adjustment, and this is held in position with a clamp/handle screw.

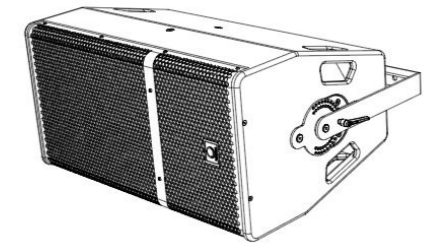

If the swivel bracket is to be bolted to a ceiling or other surface, then secure the bracket first.

To attach the MC12-P-SB, start by adding the large plate to the bottom of the speaker, using the existing M10 screws. It covers the pole mount holes as shown.

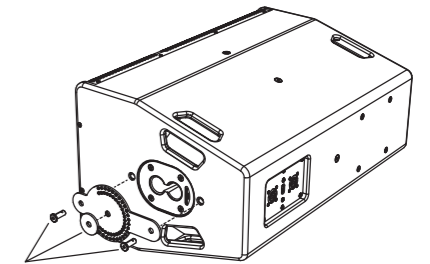

Center the large washer, and then add the swivel bracket and secure it with the center screw. Set the speaker at the desired angle and insert and tighten the handle screw.

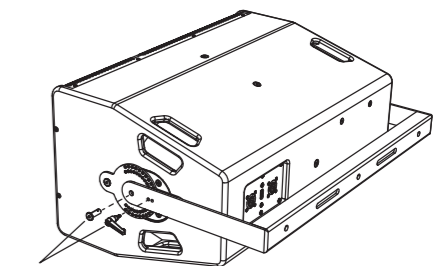

Secure the other end of the swivel bracket with the existing M10 mounting screw as shown. There is a large washer there as well.

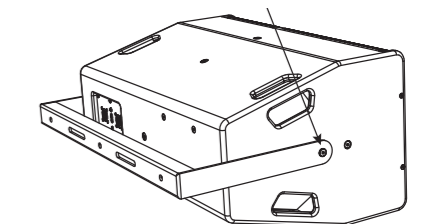

Horn Rotation

The MF/HF Horn assembly is asymmetric, and gives a 40 degree horizontal beamwidth at the top, and a 100 degree beamwidth at the bottom. (This is the default orientation from the factory when the MC12-P is mounted vertically.)

The horn assembly can be removed and reinstalled in a different orientation to suit desired configurations and coverage. The horn is marked on the front with the beamwidth angles.

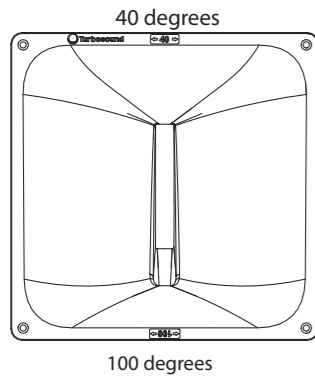

Remove the 14 screws and remove the front grill. (Note there are 2 screws in the front face of the grill, in addition to top, bottom, and sides.)

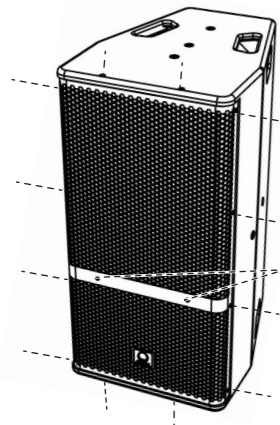

Remove the screws in each corner of the horn assembly.

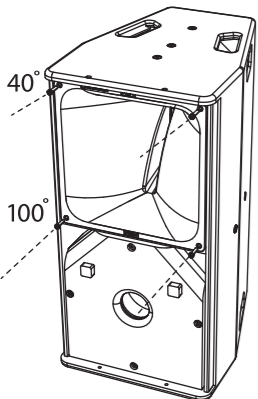

Remove the four screws at the rear of the speaker.

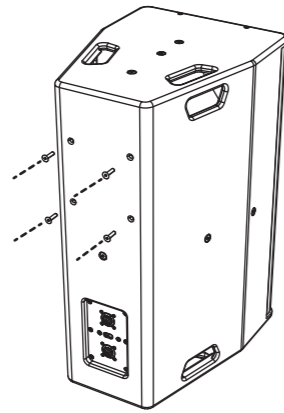

Carefully pull the horn assembly forward, just enough to be able to rotate the assembly to the desired orientation. (This example is exaggerated.)

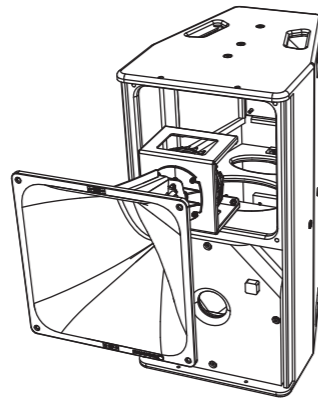

Reinstall the horn with the 4 screws at the front and 4 at the rear. Make sure the wiring is intact and not pinched.

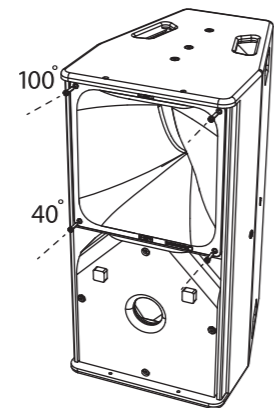

Reinstall the grill and secure with all the screws. (Make a note that the speaker has been modified.)

If the speaker is used in landscape mode, rotate the horn so the 40 degree mark is at the top. (This is a typical example of the need for horn rotation.)

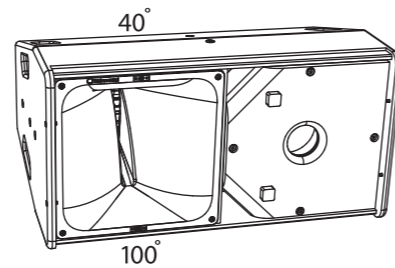

Lake Preset Overlays and Application Notes

All Manchester series Loudspeakers exclusively use Lake XP pre-sets via Lab Gruppen PLM+ and D series L platforms. No other amplifier and DSP platforms are supported.

The Manchester series has a powerful yet simple pre-set strategy utilizing the latest functionality of Lake software, along with new acoustic compensation overlays for length of array and throw distances required.

Pre-set data is found either via the Lake Load Library, or can be downloaded from www.turbosound.com

MV212, MV212-XV, MV210-HC & MC12-P loudspeakers each have individual Bi-AMP FIR base pre-sets: Full range with or without MS Subwoofers.

The MC12-P also has presets for bi-amp mode (2 channel DSP/AMP) and passive mode (1 channel DSP/AMP).

CAUTION: Do not combine MV212 / MV212XV / MV210-HC / MC12-P loudspeakers on the same amplifier / DSP circuit. Failure to follow these instructions may lead to damage to the equipment.

CAUTION: Pay careful attention to output patching.

MV212, MV212-XV, MV210-HC, MC12-P, and MS Subwoofer modules are based on the XP module from Lake software.

This QSG refers to REV2.1 XP presets.

CAUTION: REV1.1 (older 'FIR3way' modules) and REV2.1 XP modules ARE NOT COMPATIBLE IN THE SAME SYSTEM.

Lake software V7.0.7 or above must be used.

Lake XP signal flow:

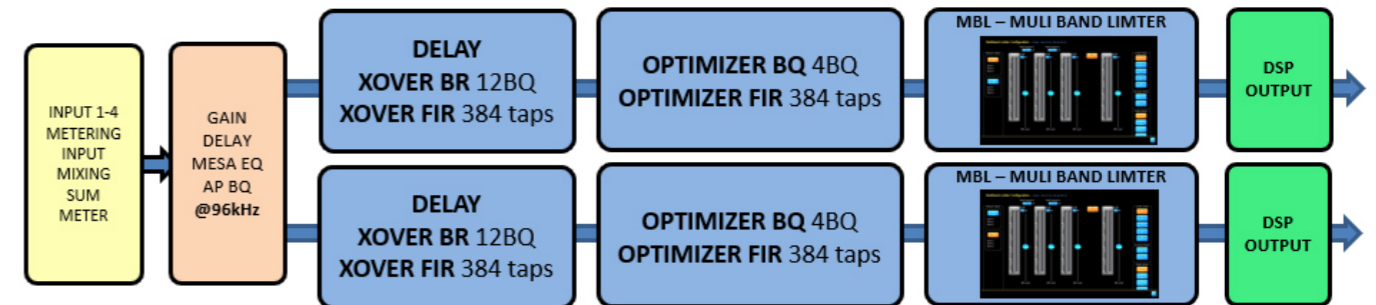

The download of the Lake controller includes the Lake Controller Operation Manual, which is a full tutorial of the Lake Controller and compatible hardware such as PLM+ series amplifiers

Within this QSG, we focus on the Turbosound Manchester series workflow and pre-set strategy, and assume basic working knowledge of the Lake Controller.

DESCRIPTION
1.1: Frame (Amplifier) is in the Main workspace page
Here we can see a default PLM12k44 frame with no DSP pre-set modules loaded.

OVERLAY

How to load a module from the Lake Load Library:
Left-click on Module A in the frame.
Module A is now outlined in yellow, and the buttons at the bottom of the workspace show various module options. The Modules button is also highlighted there.

OVERLAY

To Load a module :
Click the ' Module Store/Recall' button.

OVERLAY

DESCRIPTION
Folders now appear, and these allow you to select where to recall the module (pre-set) from.
Double click the "Lake Load Library 5.5" folder.

OVERLAY

Scroll using the arrow keys >> << along the bottom, to find the "Suitable for Turbosound Loudspeakers" folder, then double click to open it.

OVERLAY

Now scroll again >> << to find the "Manchester REV2.1 XP" folder, then double click to open it.
CAUTION: Do not open the "Manchester" folder as this contains older REV1.1 FIR3way modules which are replaced by REV2.1 XP in October 2022. Note that this QSG only refers to the REV2.1 XP module.

OVERLAY

DESCRIPTION
Three folders appear. Double click "Modules"

CAUTION: Do not open "Array Size Comp" or "Distance EQ." These are EQ overlays for the other speakers in the Manchester series.

OVERLAY

The available module folders are displayed.

The Manchester MC12-P has two options: PASSIVE and BI-AMP

Left-click on either of these to show more details about the module set up. This example shows the PASSIVE option.

TIP: Please read the information!

OVERLAY

Double-clicking the desired 'modules' folder will open the module pre-set in the highlighted module of the Frame (amplifier)

OVERLAY

Press 'YES' to proceed—the selected pre-set module is loaded!

OVERLAY

DESCRIPTION
Output Configuration:
Now you can patch the DSP module output to the frame's amplifier outputs

For the full range 'PASSIVE' mode (as shown here) we want full range to pins 1. The patch is highlighted in yellow boxes with red text

For the 'BI-AMP' mode we want Low to pins 1 and high to pins 2. The patch is highlighted in yellow boxes with red text

Once you have finished the correct output patch, press enter to close the output configuration

Note: you will get access to the screen once you go through the same process to load other pre-set modules into the free C & D modules or via the IO option button

OVERLAY

Now you can see the pre-set module is recalled and loaded into A/B hardware modules

OVERLAY

Note: In 2 way 'BI-AMP' mode, 2 channels of DSP and Amplifier are required

OVERLAY

In 1 way 'PASSIVE' mode (full range), only 1 channel of DSP and Amplifier are required

OVERLAY

EQ STRATEGY

The MC12-P has a 3 band EQ (BLEQ) inserted on both options of module (1W PASSIVE and 2W BI-AMP)

The BLEQ acts as a level control for LF/MF/HF and the 3 centre frequencies of the BLEQ relate to the crossover points of the LF/MF/HF

The level control for the LF and MHF has been disabled to maintain optimum phase response hence the BLEQ is offered for users to adjust tonal balance of the system along with PEQ overlay and group overlays (system design dependant)



Examples of BLEQ use

3 Band EQ

1 dB Cut in LF

1 dB Boost in HF



3 Band EQ

3 dB Boost in LF



EQ STRATEGY

3 Band EQ

1 dB Boost in HF





NOTE: When in another overlay, you can see any changes made in the 3 band EQ (BLEQ) – this example shows a 3dB boost in LF, while in the PEQ1 overlay



This example shows the EQ point made in the BLEQ

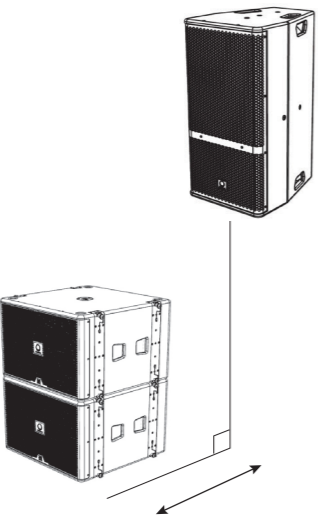

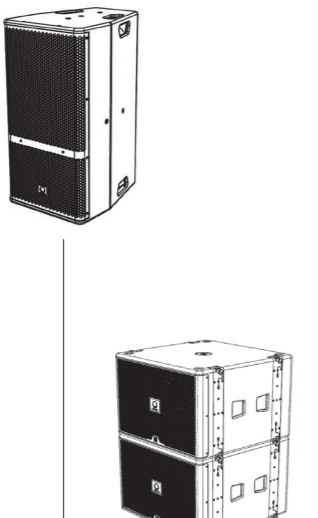
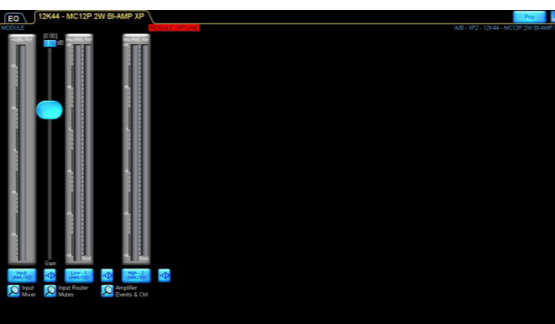
SUBWOOFER TIME ALIGNMENT	ILLUSTRATION	OVERLAY
<p>The MS121 subwoofer pre-sets use all-pass filters to set the initial time alignment (assuming the fronts of the cabinets are in line) this greatly reduces system latency.</p> <p>For example: If the fronts of the MC12-P and MS121 are aligned, then in both pre-sets, the delay should be set to the default, which is 0ms.</p> <p>However, it is not always possible to have the flown speakers and the ground stacked bass aligned in the vertical plane.</p> <p>1. In this example, the MS121 subs are 'forward' of the MC12-P, and so the MS121 subs need to be delayed.</p>	<p>1. Subs are forward</p> 	 <p>Delay adjustment of subwoofers</p>
<p>2. In this example, the flown MC12-P is 'forward' of the MS121 ground stacked subs, and so the MC12-P needs to be delayed.</p> <p>How do you find the correct delay time to align the flown speakers to the ground stacked bass?</p> <p>Some basic knowledge of delay units can get you an acceptable result by measuring the distance between the fronts of the flown speaker and the front of the ground stacked array. Remember within Lake software you can choose the delay unit; ms, m, or feet.</p> <p>1 ms (milliseconds) = 0.343 m (meters) = 1.125 ft (feet)</p> <p>Further fine-tuning can be done by using one of the many industry standard measurement software systems, reference microphones and sound-cards. Lake software offers integration to many of these software systems, and further information can be found at www.labgruppen.com</p>	<p>2. Flown MC12-P is forward</p> 	 <p>Delay adjustment of MC12-P</p>

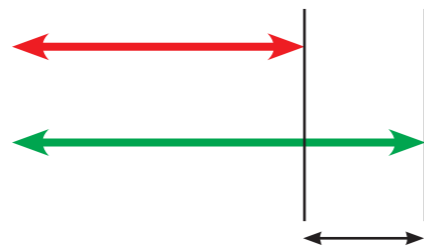

Distance (time) is the difference to add to the flown array for alignment at the listening point

Dimensions MC12-P

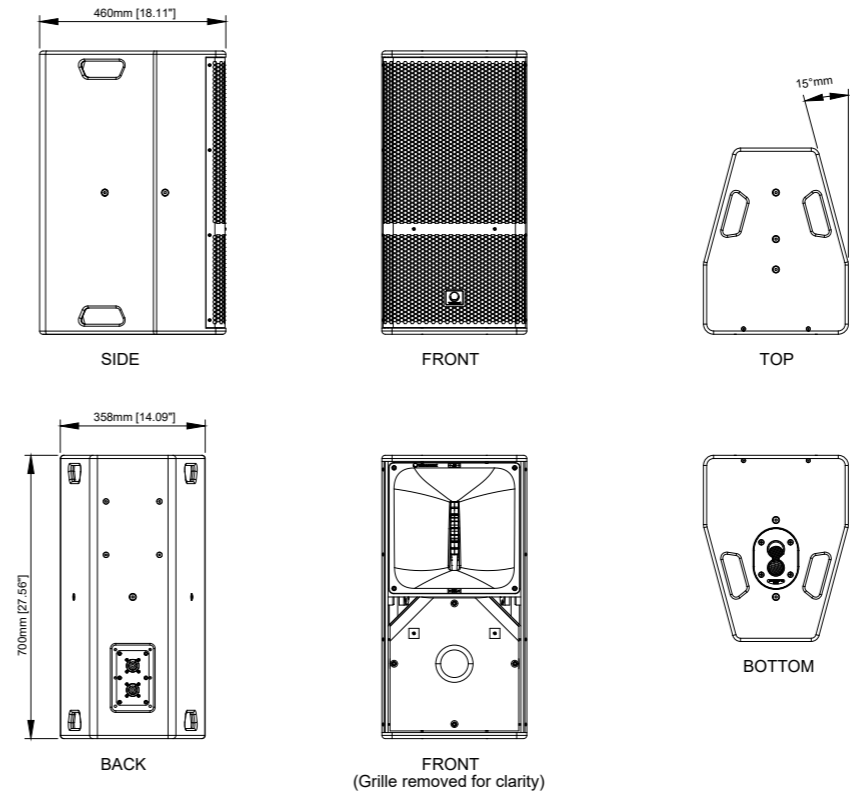

MC12-P-SB

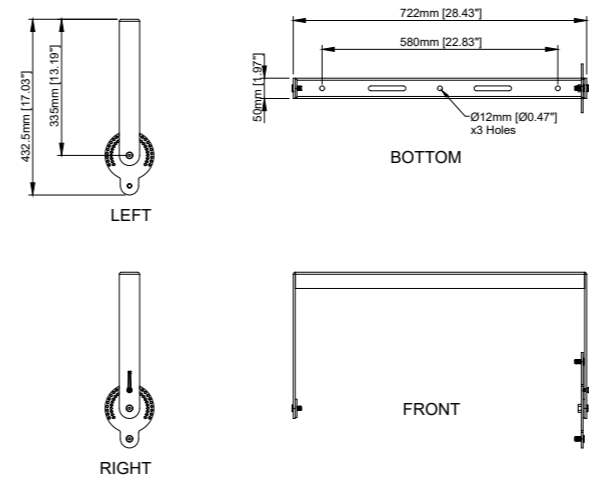

MC12-P-YB

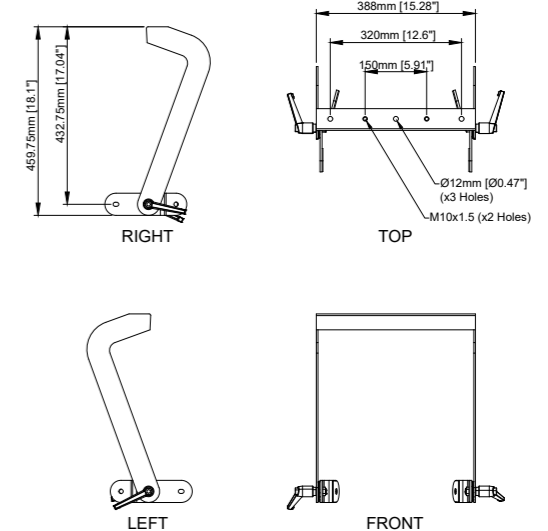

TQ-FB

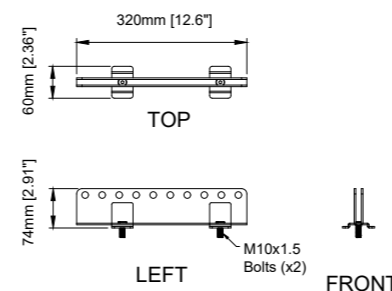

SA-35

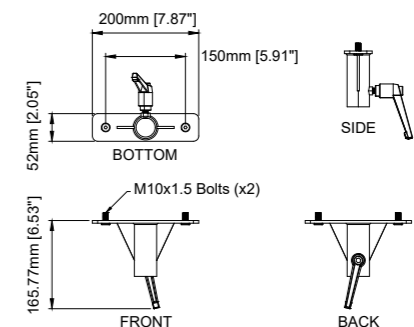

Specifications

EN

MC12-P

System	
Frequency response (± 3 dB) ¹	55 Hz - 20 kHz
Frequency response (-10 dB) ¹	39 Hz - 20 kHz
Nominal dispersion	40-100 degrees asymmetrical (H) x 30 degrees (V)
Power handling (IEC)	LF: 500 W continuous
	MHF: 190 W continuous
	FR: 690 W continuous
Sensitivity	LF: 101 dB (1 W @ 1 m) ²
	MHF: 114.5 dB (1 W @ 1 m) ²
Maximum SPL	138 dB (passive mode) / 140 dB (bi-amp mode) ³
Impedance	LF: 8 Ω / MHF: 12 Ω
	FR: 8 Ω
Crossover type	External bi-amp and internal passive
Components	1 x 12" (315 mm) LF driver
	1 x 1.4" (35 mm) exit, large format dual compression driver
IP Rating	54
UV Rating	4-5
Enclosure	
Connectors	2 x speakON NLT4MP STX
Wiring	Bi-amp mode: Pins 1+ / 1- LF, pins 2+ / 2- HF Passive mode: Pins 1+ / 1- input, pins 2+ / 2- link
Dimensions H x W x D	700 x 358 x 460 mm (27.6 x 24 x 18.1")
Net weight	28.5 kg (62.8 lbs)
Construction	15 mm (enclosure) and 18 mm (front) marine birch plywood, vented and internally braced
Finish	Polyurethane black, with custom colours on request
Grille	Powder coated perforated steel
Flying hardware	Integral suspension system and M10 x 12 points with dedicated yoke, swivel and fly-bar accessories
Accessories	
Yoke Bracket	MC12-P-YB
Pole Mount Bracket	SA-35
Swivel Bracket	MC12-P-SB
Fly Bar	TQ-FB

- Notes
1. Average over stated bandwidth. Measured at 1 metre on axis.
 2. SPL level at 1 m under free field conditions, using pink noise with crest factor 4, with dedicated pre-set.
 3. Average Peak level over overlap bandwidth. Measured at 1 metre on axis with dedicated pre-set.
 4. Peak level at 1 m under half space conditions using pink noise with crest factor 4, with dedicated pre-set. Ease Data can be downloaded from www.turbosound.com

Other important information

EN Important information

1. Register online. Please register your new Music Tribe equipment right after you purchase it by visiting musictribe.com. Registering your purchase using our simple online form helps us to process your repair claims more quickly and efficiently. Also, read the terms and conditions of our warranty, if applicable.

2. Malfunction. Should your Music Tribe Authorized Reseller not be located in your vicinity, you may contact the Music Tribe Authorized Fulfiller for your country listed under "Support" at musictribe.com. Should your country not be listed, please check if your problem can be dealt with by our "Online Support" which may also be found under "Support" at musictribe.com. Alternatively, please submit an online warranty claim at musictribe.com BEFORE returning the product.

3. Power Connections. Before plugging the unit into a power socket, please make sure you are using the correct mains voltage for your particular model. Faulty fuses must be replaced with fuses of the same type and rating without exception.



Hereby, Music Tribe declares that this product is in compliance with Directive 2011/65/EU and Amendment 2015/863/EU, Directive 2012/19/EU, Regulation 519/2012 REACH SVHC and Directive 1907/2006/EC, and this passive product is not applicable to EMC Directive 2014/30/EU, LV Directive 2014/35/EU.

Full text of EU DoC is available at <https://community.musictribe.com/>

EU Representative: Music Tribe Brands DK A/S
Address: Gammel Strand 44, DK-1202 København K, Denmark

UK Representative: Music Tribe Brands UK Ltd.
Address: 8th Floor, 20 Farringdon Street London EC4A 4AB, United Kingdom

