

Xw12

X-Array™ Two-Way, Full-Range Floor Monitor

- New 12-inch woofer design provides improved internal damping of cone
- New DH6, 1.4-inch compression driver
- Rugged 12-ply ultracompact, uniquely curved enclosure
- Constant-directivity 80° x 55° horn
- Professional Neutrik Speakon® paralleled pass-through connectors on both ends of enclosure

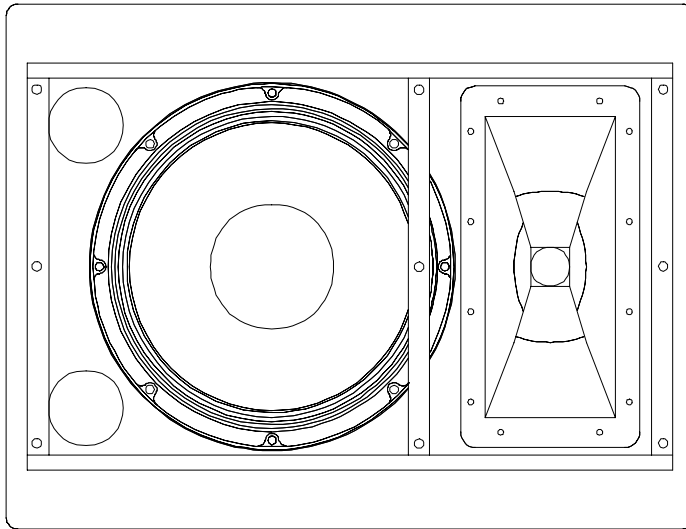

Description

The Electro-Voice Xw12 full-range, two-way, floor monitor loudspeaker system is part of the Electro-Voice X-Array™ series and is intended for high-level sound reinforcement in fixed-installation and touring-sound applications. The Xw12 is a full-range biamped floor monitor speaker system which may be used with the Electro-Voice Dx38 digital crossover, the Klark Teknik DN8000 or any high-quality, signal-controller system. The Xw12 employs a custom-designed, 12-inch woofer for low-frequency reproduction. Designed as part of the Xw12 development, this woofer uses a new cone material to provide maximum internal damping. This woofer also employs "DL" technology which utilizes a Thermal Inductive Ring, (TIR™), a nonmagnetic pole piece extension that controls inductance and, most importantly, provides a major heat transfer path from the top of the voice coil to minimize power compression. For high frequencies, the Xw12 uses the DH6, a 1.4-inch-exit variant of the DH1A compression driver designed as part of the Xw12 development. Its unique one-piece geometrically optimized titanium dome and suspension combined with its unusually powerful magnetic motor provide maximum efficiency and precise control of the diaphragm mo-

tion. The compression driver is coupled to an 80° x 55° horn. This flat-front, constant-directivity horn is based on the Electro-Voice HP series, and is geometrically optimized for performance from 1,250-20,000 Hz. The XW12 is constructed of 18-mm void-free, 3/4-inch 12-ply curved plywood shell which is extremely rigid. The baffle and end pieces are made from 18-mm 13-ply birch plywood. This high-strength enclosure is sprayed with a resilient, textured black finish for a truly professional appearance. The end-mounted, recessed handle makes transportation relatively easy.

Applications

The XW12 loudspeaker system is ideal for use as a professional stage touring or installation application floor monitor where extremely high power and low distortion, as well as accurate vocal coverage and maximized intelligibility are required from a system housed in a compact, low-profile enclosure. Its symmetrical design will allow two monitors to be placed head to head so that the high-frequency horns are coupled for high-level large stage applications. The Xw12 and associated controller combinations are recommended for applications requiring full bandwidth down to 60 Hz.

Power-Handling Test

Electro-Voice components and systems are manufactured to exacting standards to ensure reliability in continuous use in arduous real-life conditions. Besides utilizing industry-standard power tests, extreme in-house power tests which push the performance boundaries of the loudspeakers are also performed for an extra measure of reliability. The XW12 systems are rated per ANSI/EIA RS-426-A Loudspeaker Power Rating, Full Range Test, which uses a shaped-random-noise signal to simulate typical music to test the mechanical and thermal capabilities of the loudspeakers. The Dx38 digital electronic unit was used to provide the necessary crossover filters and equalization during power testing. Specifically, the Xw12 passes the ANSI/EIA RS-426-A power test with the following test parameters:

Low-Frequency Section:

$P_{E(MAX)}$:	300 watts
Test Voltages:	47.0-volts rms 94.0-volts peak
$R_{SR}(1.15 R_E)$:	7.36 ohms

High-Frequency Section:

$P_{E(MAX)}$:	75 watts
Test Voltages:	28.0-volts rms 54.0-volts peak
$R_{SR}(1.15 R_E)$:	10.5 ohms

Xw12 Two-Way, Full-Range Floor Monitor

Crossover, Equalization and Time-Delay Controller

The Xw12 speaker system was designed as an integrated package that utilizes the Electro-Voice Dx38 digital crossover system.

The Dx38 features a 125-Hz crossover frequency utilizing 24-dB-per-octave Linkwitz-Riley filters, and contains time delay and equalization for optimum performance of the Xw12.

Electrical Connection and System Wiring

Electrical connections to the Xw12 are made on the sides of the enclosure via parallel pass through 4-pin connectors. There are two connectors on each of the input panels to allow paralleling of other Xw12 systems. The Neutrik Speakon® NL4MPR is used for both connections. The pin assignments are as follows:

Pin 1+: LF(+)

Pin 1-: LF(-)

Pin 2+: HF(+)

Pin 2-: HF(-)

The wiring diagram of the loudspeaker system is shown in Figure 7. The electrical impedance is shown in Figure 6.

Amplifier Requirements

Power amplifiers with the following ratings are recommended for use with the Xw12 speaker systems:

LF: 600 watts per channel into 8 ohms.

HF: 600 watts per channel into 8 ohms.

Xw12 speakers may be paralleled only with other Xw12 speakers if the amplifier is capable of delivering full power at the lower impedances. The use of amplifiers with lower power ratings is acceptable; however, the full-power capabilities of the Xw12 speakers will not be realized. The use of amplifiers with significantly higher power ratings will generate maximum dynamic range and fidelity, but care must be utilized for longer duration signals as mechanical and thermal damage are possible in the system. Under certain circumstances, higher rated amplifiers are acceptable. It is acceptable to drive the Xw12 speakers with a stereo power amp utilizing one channel to drive

the low frequencies and the other channel to drive the high frequencies.

Field Replacement

The Xw12 may be serviced in the following ways. Remove the grille to allow access to both the woofer and high-frequency driver. Remove the woofer bolts to allow the woofer to easily be removed for repair or replacement. In case of a compression driver failure, a diaphragm assembly replacement kit is available. To remove the compression driver, remove the horn-mounting screws. Remove the woofer to gain access to the compression driver. Remove the two accessible hex socket screws attaching the horn to the driver through the woofer cut-out opening. After removing the screws, lift the high-frequency horn and rotate 180 degrees allowing access to remove the remaining screws. Remove the compression driver through the woofer cut-out opening. If desired, the complete driver may be returned for service.

The following replacement parts are available from EVI Audio Service in Buchanan, Michigan:

LF: Complete woofer: EV Part No. 812-2997

HF: Diaphragm kit: EV Part No. 84233-XX

Architects' And Engineers' Specifications

The loudspeaker speaker system shall be a two-way biamped system with performance controlled by a variety of dedicated electronic control units. The loudspeaker system shall have a 305-mm (12-inch) direct-radiating driver with an 8-ohm, 63.5-mm (2.5-inch) voice coil constructed of aluminum wire, and shall be capable of a 300-watt shaped pink-noise signal with a 6-dB crest factor for eight hours (as per ANSI/EIA RS-426-A 1980). The loudspeaker system shall have a 35.6-mm (1.4-inch) exit compression driver mounted on a high-frequency horn. The compression driver shall have 76.2-mm (3.0-inch) diameter, titanium dome and a 16-ohm nominal, 76.2-mm (3.0-inch) diameter voice coil constructed of aluminum wire, and shall be capable of handling a 75-watt, 1,600-20,000-Hz pink-noise signal with a 6-dB crest factor for eight hours (as per ANSI/EIA RS-426-A 1980 standard). The high-frequency horn shall be of the constant-directivity type and shall

produce a nominal horizontal beamwidth (6-dB-down angle) of 80° from 2,000-20,000 Hz and a nominal vertical beamwidth of 55° from 1,600-20,000 Hz. The loudspeaker system enclosure shall be constructed of 18-mm thick, 12-ply flat birch plywood and .75-inch thick, 12-ply curved birch plywood, covered with black textured paint and shall have a 14-gauge perforated steel grille.

When used with the electronic control unit, the loudspeaker system shall have a flat on-axis frequency response from 60 -16,000 Hz. The loudspeaker enclosure dimensions shall be 358.3 mm (14.11 in.) high, 584.2 mm (23.00 in.) wide and 408.8 mm (16.10 in.) deep and shall weigh 28.2 kg (62 lb).

The loudspeaker shall be the Electro-Voice Xw12.

Uniform Limited Warranty

Electro-Voice products are guaranteed against malfunction due to defects in materials or workmanship for a specified period, as noted in the individual product-line statement(s) below, or in the individual product data sheet or owner's manual, beginning with the date of original purchase. If such malfunction occurs during the specified period, the product will be repaired or replaced (at our option) without charge. The product will be returned to the customer prepaid. Exclusions and Limitations: The Limited Warranty does not apply to: (a) exterior finish or appearance; (b) certain specific items described in the individual product-line statement(s) below, or in the individual product data sheet or owner's manual; (c) malfunction resulting from use or operation of the product other than as specified in the product data sheet or owner's manual; (d) malfunction resulting from misuse or abuse of the product; or (e) malfunction occurring at any time after repairs have been made to the product by anyone other than Electro-Voice Service or any of its authorized service representatives. Obtaining Warranty Service: To obtain warranty service, a customer must deliver the product, prepaid, to Electro-Voice Service or any of its authorized service representatives together with proof of purchase of the product in the form of a bill of sale or receipted invoice. A list of authorized service repre-

Xw12 Two-Way, Full-Range Floor Monitor

representatives is available from Electro-Voice Service at 600 Cecil Street, Buchanan, MI 49107 (800-234-6831 or FAX 616-695-4743). Incidental and Consequential Damages Excluded: Product repair or replacement and return to the customer are the only remedies provided to the customer. Electro-Voice shall not be liable for any incidental or consequential damages including, without limitation, injury to persons or property or loss of use. Some states do not allow the exclusion or limitation of incidental or consequential damages so the above limitation or exclusion may not apply to you. Other Rights:

This warranty gives you specific legal rights, and you may also have other rights which vary from state to state.

Electro-Voice Speakers and Speaker Systems are guaranteed against malfunction due to defects in materials or workmanship for a period of five (5) years from the date of original purchase. The Limited Warranty does not apply to burned voice coils or malfunctions such as cone and/or coil damage resulting from improperly designed enclosures. Electro-Voice active electronics associated with the speaker systems are guaranteed for three (3) years from the date of original purchase. Additional de-

tails are included in the Uniform Limited Warranty statement.

Electro-Voice Accessories are guaranteed against malfunction due to defects in materials or workmanship for a period of one (1) year from the date of original purchase. Additional details are included in the Uniform Limited Warranty statement.

For warranty repair, service information, or a listing of the repair facilities nearest you, contact the service repair department at: 616/695-6831 or 800/685-2606.

For technical assistance, call: 800/234-6831. Specifications subject to change without notice.

Figure 1—Polar Response (5 dB per division)

The directional response of the system was measured in an anechoic environment at a distance of 6.1 m (22 ft) using 1/3-octave-filtered pink noise with a full spherical measurement system. The Dx38 digital electronic unit was used to provide the necessary crossover filters, equalization and time delay. The polar response of the loudspeaker system at selected 1/3-octave frequencies is shown. The selected frequencies are representative of the polar response of the system.

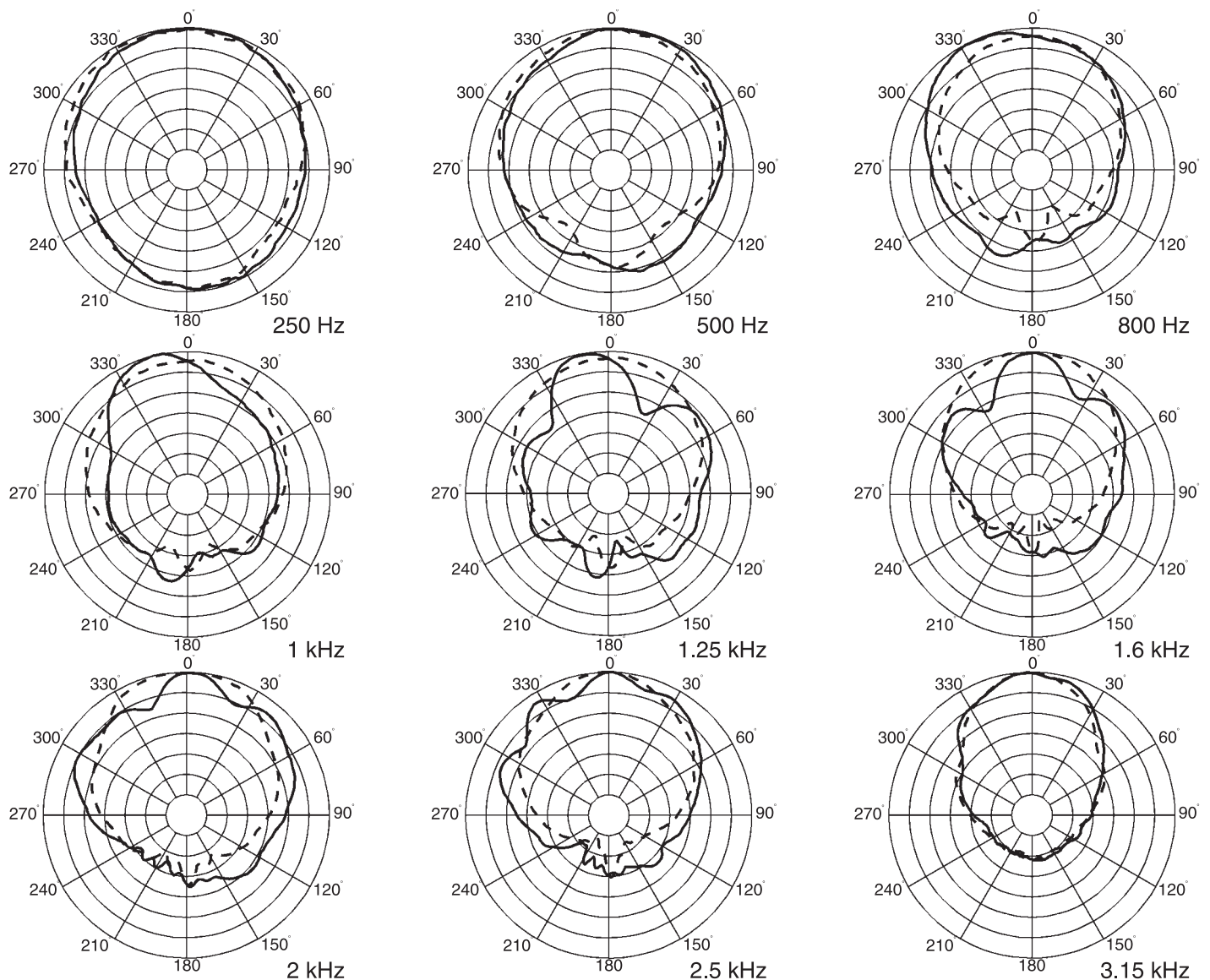

Xw12 Two-Way, Full-Range Floor Monitor

Xw12 Two-Way, Full-Range Floor Monitor

XW12 Two-Way, Full-Range Floor Monitor

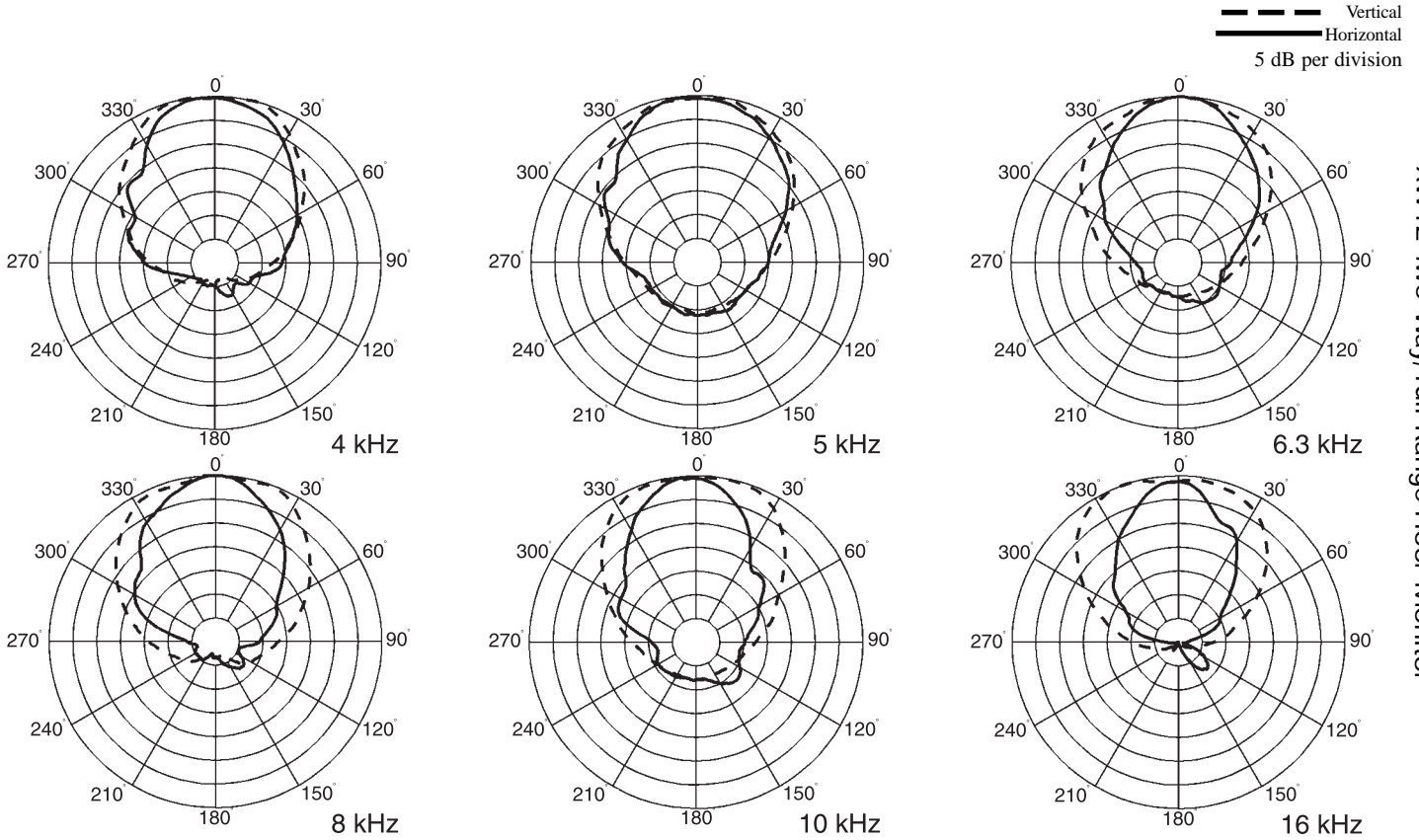

Figure 2—Frequency Response

The frequency response of the system was measured on axis in the farfield in an anechoic environment using a swept sine-wave signal. The Dx38 digital electronic unit was used to provide the necessary crossover filters, equalization and time delay. One watt of power (2.83 volts rms at 400 Hz) was applied to the midband of the low-frequency section. The sound-pressure level was normalized for an equivalent one meter distance.

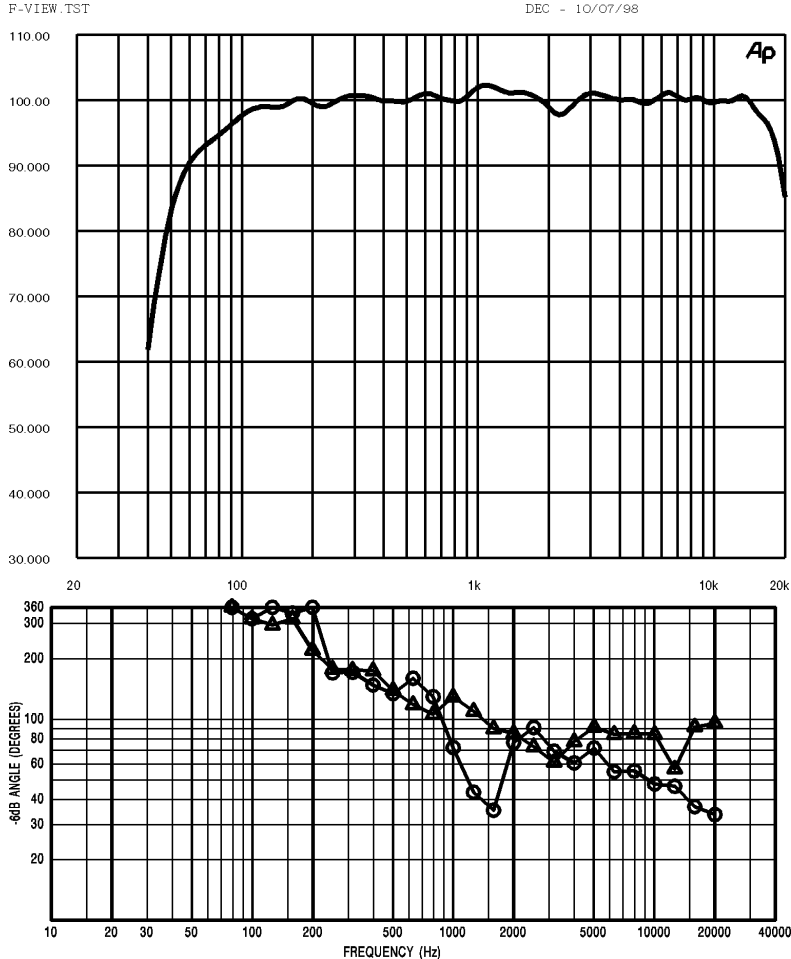

Figure 3—Beamwidth

The beamwidth of the system, (i.e., the included horizontal and vertical coverage angles at the 6-dB-down point) was measured with a full spherical measurement system as described in "Polar Response."

Xw12 Two-Way, Full-Range Floor Monitor

Figure 4—Directivity

The directivity index, D_i , and directivity factor $R_0(Q)$, of the system were measured with a full spherical measurement system as described for the "Polar Response."

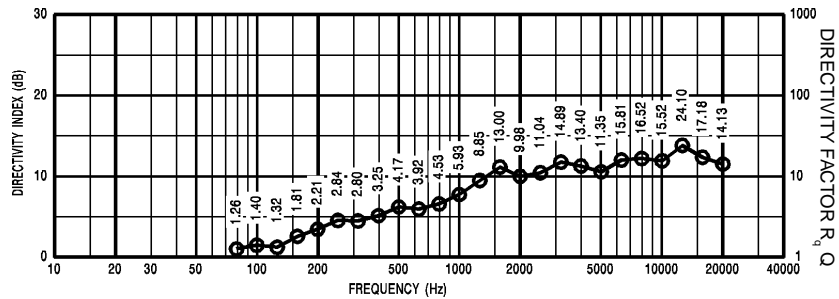

Figure 5—Distortion

Distortion for the system was measured on axis in the farfield in an anechoic environment with an input signal that would result in a sound-pressure level of 115 dB at one meter. The Dx38 digital electronic unit was used to provide the necessary crossover filters, equalization and time delay. A frequency spectrum typical of close-miked rock music was employed. The sound-pressure level was normalized for an equivalent one-meter distance. Plots of second and third harmonic distortion are shown referenced to the fundamental.

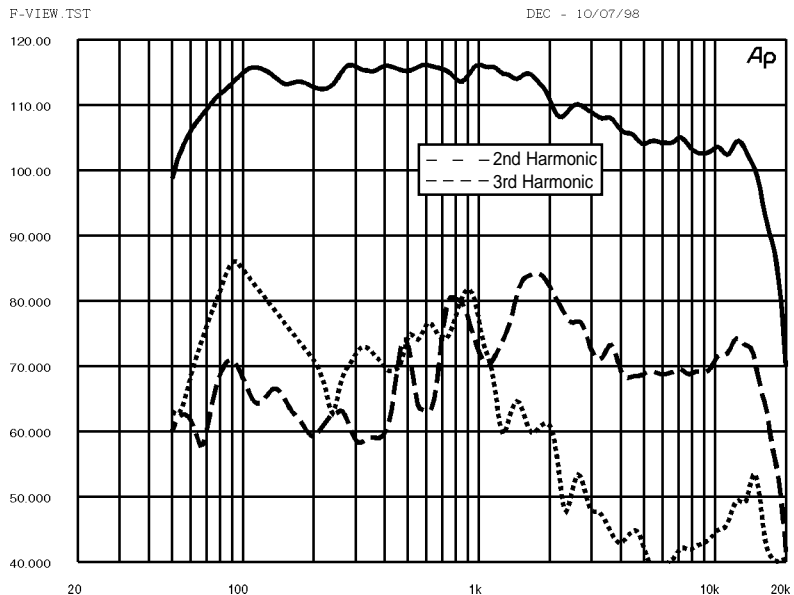

Figure 6—Impedance

The impedance of each frequency band of the system was measured in an anechoic environment.

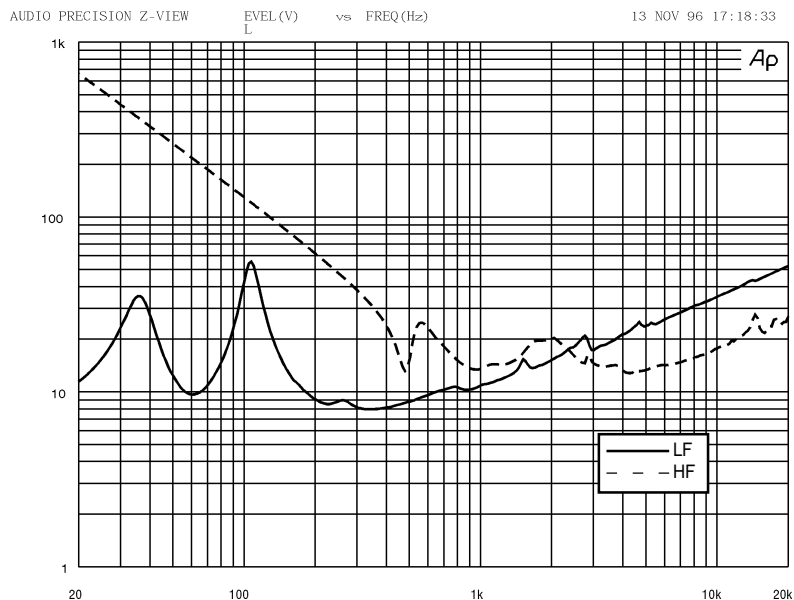
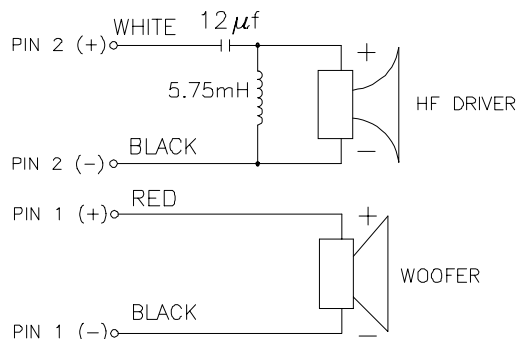

Figure 7—Wiring

The wiring diagram of each frequency band of the system is shown.



Xw12 Two-Way, Full-Range Floor Monitor

Figure 8—Dimensions

Xw12 Two-Way, Full-Range Floor Monitor

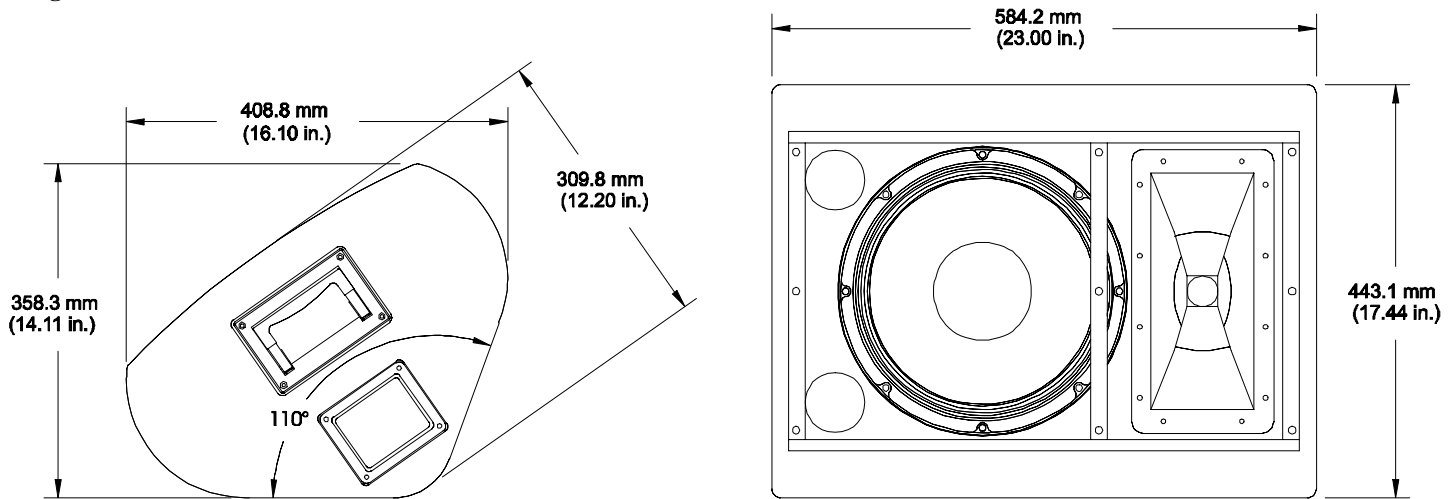

Specifications

Frequency Response (measured in far field, calculated to one meter on axis, swept sine wave, one watt into LF section 2.83 V at 400 Hz, anechoic environment; see Figure 2):

60-16,000 Hz

Crossover Frequency:

1,250 Hz

Efficiency, LF/HF:

4.8/25 %

Maximum Long-Term-Average Power-Handling Capacity (per ANSI/EIA RS-426A 1980), LF/HF:

300/75 watts

Maximum Long-Term-Average Midband Acoustic Output, LF/HF:

14/18.8 acoustic watts

Sensitivity (SPL at one meter, indicated input power, anechoic environment, average level), LF/HF,

1/1 watt:

99.0/110.0 dB

300/75 watts:

124.0/129.0 dB

Beamwidth (angle included by 6-dB-down points on polar responses, indicated one-third-octave bands of pink noise; see Figures 1 and 3),

Horizontal, 1,200-16,000 Hz:

80° (+25°, -20°)

Vertical, 1,200-16,000 Hz:

55° (+25°, -20°)

Directivity Factor, R_0 (Q), 1,200-16,000 Hz Average (see Figure 4):

14.3 (+9.8, -5.4)

Directivity Index, D_i , 1,200-16,000 Hz Average (see Figure 4):

11.6 dB (+2.3 dB, -2.1 dB)

Distortion (115 dB SPL at one meter, shaped spectrum; see Figure 5),

Second Harmonic,

100 Hz:

0.5 %

500 Hz:

0.8 %

2,000 Hz:

3.7 %

5,000 Hz:

1.7 %

Third Harmonic,

100 Hz:

3.3 %

500 Hz:

0.9 %

2,000 Hz:

0.3 %

5,000 Hz:

<0.1 %

Transducer Complement,

HF:

DH6 driver, HP-type 80°x 55° horn

LF:

DL-type 12-in. woofer

Impedance (see Figure 6),

Nominal, LF/HF:

8/16 ohms

Minimum, LF/HF:

8.2/10.5 ohms

Input Connections:

Two Neutrik NL4MPR Speakon® connectors paralleled on each side of enclosure

Recommended Amplifier Power,

HF:

600 watts per channel @ 8 ohms

LF:

800 watts per channel @ 8 ohms

Enclosure Construction,

Enclosure Shell:

3/4-in., 12-ply curved birch plywood

18-mm, 13-ply flat birch plywood

Finish:

Black textured paint

Grille:

14-gauge perforated steel

Dimensions,

Height (front):

443.1 mm (17.44 in.)

Height (profile):

358.3 mm (14.11 in.)

Width:

584.2 mm (23.00 in.)

Depth (overall):

309.8 mm (12.20 in.)

Depth (profile):

408.8 mm (16.10 in.)

Angle:

110° wedge

Net Weight:

28.2 kg (62 lb)

Shipping Weight:

31.3 kg (69 lb)

Electro-Voice®

600 Cecil Street, Buchanan, MI 49107

616/695-6831, 616/695-1304 Fax

©Telex Communications, Inc., 1999 • Litho in U.S.A.

SPEAKERS—X-Array™

Part Number 534226 Rev. B—9934