

Crestron Flex Tabletop Large Room Video Conference System

The UC-M70-U Crestron Flex tabletop conferencing system provides a large room video conference solution for open-platform UC applications. It supports a single video display and features a Crestron Flex tabletop conference device and an AVer® Camera.



In the Box

Tabletop Conference Device

- 1 Tabletop Conference Device (6508083)
- 1 Cable, CAT5e, RJ-45 - RJ-45, 12 ft (3.7 m) (2033988)
- 1 Cable Retention Plate (2047908)
- 3 Tie Wrap (2047935)

Additional Items

- 1 AVer® CAM520 PRO enterprise-grade camera (6511576)
- 1 Microphone pod (6508084)
- 1 Cable, thin HDMI®, 6 ft (1.8 m) (6510946)
- 1 Cable, HDMI, 20 ft (6.1 m) (6503567)
- 1 Cable, USB 2.0, A - Micro-B, 6 ft (1.8 m) (6510947)
- 1 Cable, USB Extension, USB Type A Male-to-Female, 15 ft (4.6 m) (6508260)
- 1 IR Emitter Probe (6500940)
- 1 Power supply (6500187)



Install the Cable Retention Plate

The included cable retention plate provides tie-down points for cables that connect to the Crestron® conference device.

Remove the adhesive backing from the cable retention plate and install it on the underside of the conference device as shown in the following diagram. Ensure the cable retention plate is firmly attached before securing cables.

CAUTION: When turning over the device, place the device on a soft surface to avoid damage.

NOTE: If a swivel mount kit ([CCS-UCA-SMK](#)) is to be used, use the cable retention bracket included with the swivel mount kit as described in the [CCS-UCA-SMK DO Guide](#) (Doc. 7882).

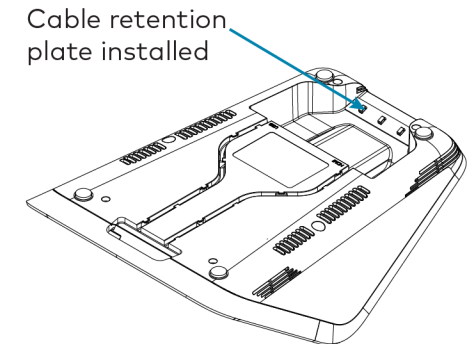
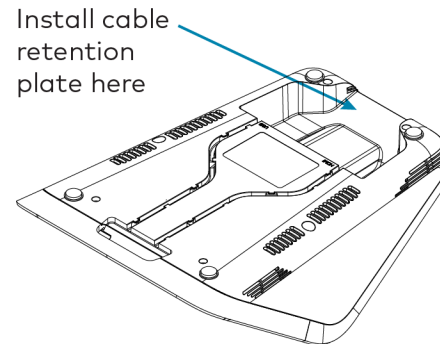

Crestron Flex Tabletop Large Room Video Conference System

Connect

Make system connections as shown below.

- CAT5e**
12 ft CAT5e cable
- HDMI**
Laptop: 6 ft thin HDMI cable
Display: 20 ft HDMI cable
- IR Emitter Probe**
7 ft integrated cable
- Microphone**
12 ft cable
- Power**
Camera
Power supply
- USB**
6 ft USB 2.0 A - Micro-B cable
15 ft USB extension cable (optional)
Camera

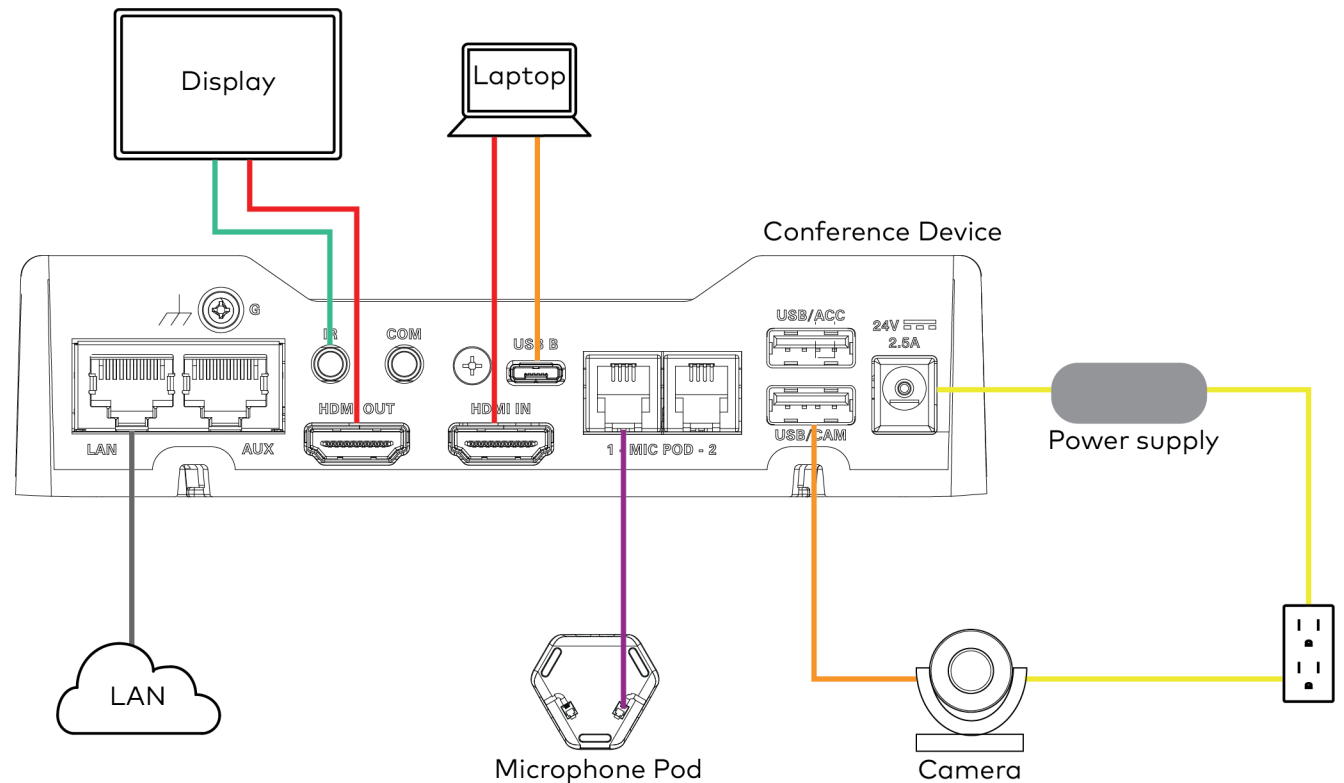

Crestron Flex Tabletop Large Room Video Conference System



Bundle Cables

Bundle the cables together and use a provided tie wrap to secure the bundle to one of the positions on the cable retention plate at the rear of the device. Avoid bundling power and data cables together.

Insert the included USB and HDMI cables into their respective cable channels as labeled on the underside of the conference device and as shown in the following image.

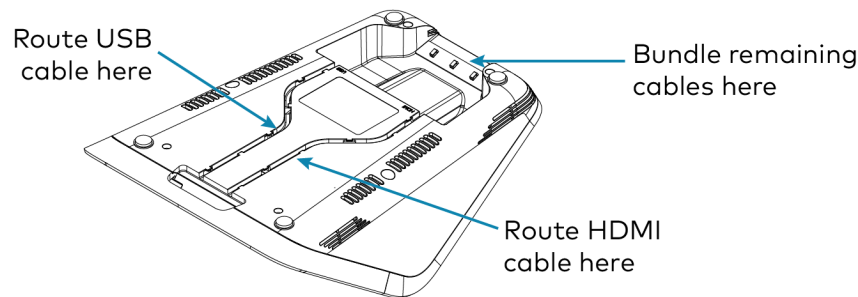

NOTES:

- When routing the USB and HDMI cables through the channels out of the front of the device, the cables do not need to be bundled. If the system design requires routing the USB and HDMI cables through the rear of the device, the cables should be bundled and secured to the cable retention plate.
- When using a swivel mount kit, do not route the USB and HDMI cables through the swivel tube.



Configure

Configure the device using the web interface. To access the web interface, enter the device's IP address into a web browser. Select the gear icon in the upper right-hand corner of the screen and enter the username ("admin") and password ("admin") when prompted.

NOTE: To find the device's IP address, tap the information icon on the device's home screen.

For detailed configuration information, refer to the [CCS-UC-1 Product Manual](#) (Doc. 7844).



Visit the Product Page

Scan the QR code to visit the product page.

UC-M70-U



www.crestron.com/model/6511603

Crestron Flex Tabletop Large Room Video Conference System

Additional Information

Original Instructions

The U.S. English version of this document is the original instructions.
All other languages are a translation of the original instructions.

Crestron product development software is licensed to Crestron dealers and Crestron Service Providers (CSPs) under a limited nonexclusive, nontransferable Software Development Tools License Agreement. Crestron product operating system software is licensed to Crestron dealers, CSPs, and end-users under a separate End-User License Agreement. Both of these Agreements can be found on the Crestron website at www.crestron.com/legal/software_license_agreement.

The product warranty can be found at www.crestron.com/warranty.

The specific patents that cover Crestron products are listed at www.crestron.com/legal/patents.

Certain Crestron products contain open source software. For specific information, visit www.crestron.com/opensource.

Crestron and the Crestron logo are either trademarks or registered trademarks of Crestron Electronics, Inc. in the United States and/or other countries. Aver is either a trademark or a registered trademark of Aver Information Inc. in the United States and/or other countries. HDMI is either a trademark or registered trademark of HDMI Licensing LLC in the United States and/or other countries. Other trademarks, registered trademarks, and trade names may be used in this document to refer to either the entities claiming the marks and names or their products. Crestron disclaims any proprietary interest in the marks and names of others. Crestron is not responsible for errors in typography or photography.

©2020 Crestron Electronics, Inc.

Doc. 8794A

09/29/20